

Specifications

Model #JJ325SRC

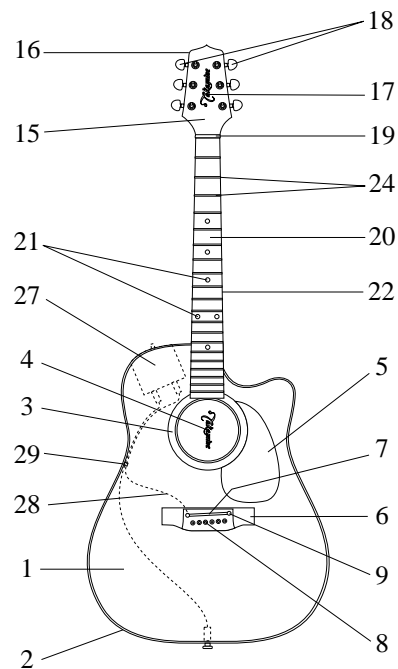

COMPONENT	DESCRIPTION
Body style	Dreadnought Cutaway
1. Top	Solid Spruce
Top Bracing	DC-1
2. Top Binding	White & Black CAB
3. Rosette	Abalone Rosette
4. Soundhole Label/Stamp	John Jorgenson Label
5. Pickguard	Ivory CAB
6. Bridge	Rosewood
7. Saddle	Bone
8. Bridge Pin	Ivory w/ Black dot
9. Bridge Inlay	White Acrylic
Bridge Bolts	N/A
10. Sides	Bubinga
11. Back	Bubinga
12. Centerline Inlay	Wood Purfling
13. Back Binding	White CAB
14. Strap Pin	End Pin Jack, Gold
15. Peghead Face	Rosewood
16. Peghead Binding	N/A
17. Peghead Logo	Abalone
18. Machine Heads	Gold w/ Pearloid buttons
19. Nut	Bone
20. Fingerboard	Rosewood
21. Fingerboard Inlay	Acrylic Dots, "JJ" / 12th fret inlay
22. Fingerboard Binding	White CAB
23. Fingerboard Side Markers	White Acrylic (#3, 5, 7, 9, 12, 15, 17)
24. Frets	Nickel
25. Neck	Mahogany
Truss Rod	Two Way Truss Rod
Neck Joint	14 Fret Dovetail
26. Heel Cap	White CAB
27. Preamp Assembly	CT4B Preamp
28. Pickup Assembly	Palathetic Pickup
29. Cord Hook	CH1
30. Serial Number	Takamine paper sticker on heel block
Strings	D'Addario EXP16 light gauge
Finish	Red Stain, Gloss Polyurethane
DIMENSIONS	(inches rounded off from metric measurements)
A. Scale Length	644 mm 25-3/8" inches
B. Nut Width	42.5 mm 1-21/32"
C. Upper Bout Width	30 cm 11-1/8"
D. Lower Bout Width	40 cm 15-3/4"
E. Total Guitar Length	104 cm 40-15/16"
F. Total Body Length	51 cm 20-1/16"
G. Upper Bout Depth	10 cm 4"
H. Lower Bout Depth	12.5 cm 4-15/16"



BODY

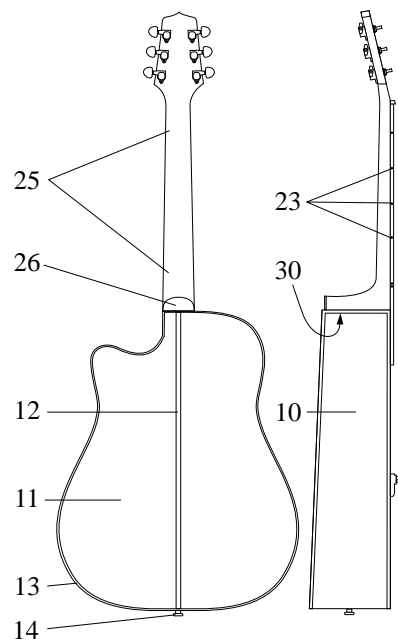

NECK

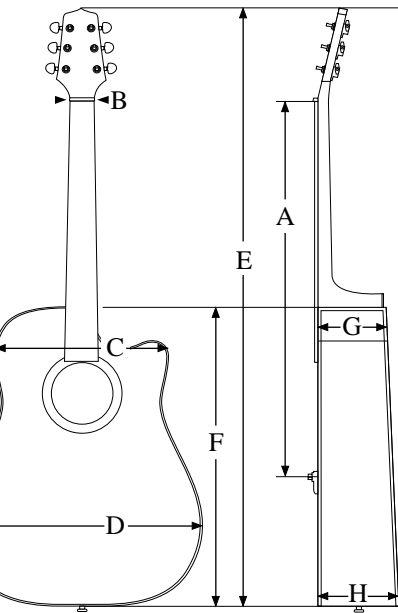

MISC